



VIVID *audio*

GIYA G1 SPIRIT

The driving spirit behind Vivid Audio
is the continuous quest for perfection.

Welcome to the G1 Spirit.

vividaudio.com

GIYA G1 SPIRIT

Welcome to the continuous quest for perfection

“It has been said that improving the G1 would be like gilding a lily. As winner of so many prestigious awards and the subject of numerous flattering reviews, there’s no question that the bar has been set very high.

Nevertheless, the driving spirit behind Vivid Audio is the continuous quest for perfection.

One such hint came from the observation that the low frequency band of the G2 and G3, while being in proportion to their sizes in simple terms such as L.F. extension, nevertheless had a subtle edge in terms of control which was perhaps attributable to the disproportionate size of the L.F. motors compared to enclosure volume. Could a similar increase give G1 an additional grip on the L.F.?

The new C225-100 was developed to prove the point: taking the voice coil from 75m to 100m and increasing its length by 50% while simultaneously lengthening the magnetic gap has resulted in a driver which excels in every way. Linear excursion is up by 30% while thermal power dissipation has doubled. Vivid Audio chassis are tailored to fit the magnet so naturally C225-100 comes with a completely new die-cast structure.

But increasing the dimensions of the magnet system comes with other consequences: because of the reaction-cancelling configuration, the new bass drivers cannot be simply dropped into the old G1 cabinet, the G1S has been completely re-designed to accommodate the new drivers and in so doing has given us the opportunity to bring G1S more in line with the aesthetic of the rest of the Giya range.



Laurence Dickie
Director

GIYA G1 SPIRIT

Designing a completely new exterior shell has also given us the opportunity to reconsider other aspects of the design including a longer wider port for increased linear LF output and the introduction of CNC machined sandwich composite stiffening braces to lower the mass of these vital components while maintaining structural performance.

Further up the acoustic spectrum the C125 lower mid-range has been subject to a complete redesign. The project began as an investigation into the re-optimisation of the form of the cone and dome assembly but with the addition of carbon fibre rings. In the same way that applying a peripheral carbon fibre ring to the D50 dome changes the optimum shape and doubles the frequency of the first break up, so the new profile of C125-75 with carbon rings has resulted in a dramatic improvement taking the first break up from 4.3 kHz to 10.5 kHz. Such a staggering improvement warranted a complete overhaul of the driver so the new cone has been complimented with a 75mm voice coil, revised magnet topology and of course a new chassis to support the new magnet system.

One of the questions which we are constantly asked is whether it is possible to connect the drivers in Vivid Audio loudspeakers in an 'active' configuration. As it is a rapidly changing field we have resisted the temptation either to develop our own system or become allied to any single manufacturer, but in order to facilitate the connection of alternative drive systems, the G1S is available with an outboard passive crossover simply connected to the loudspeaker using a professional standard NL8 connector."



Laurence Dickie
Director



GIYA G1 SPIRIT – BASS DRIVE UNIT

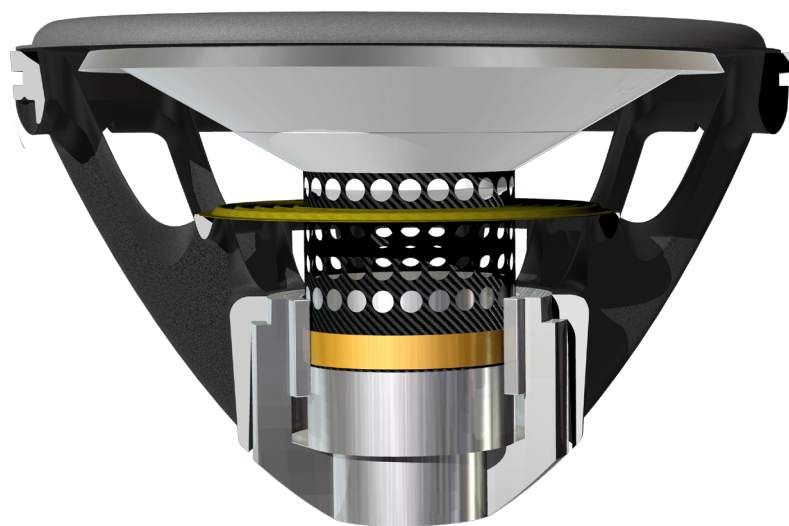

Original C225
300W

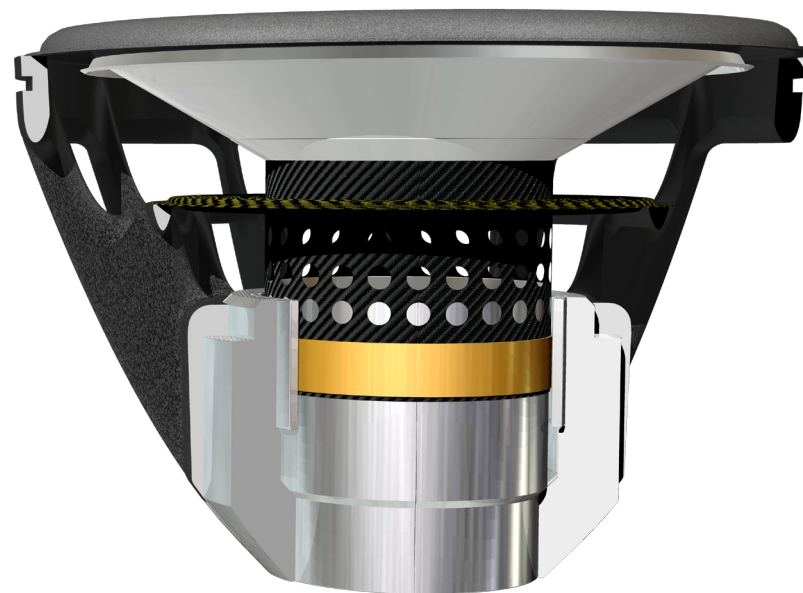

The new C225-100
600W

GIYA G1 SPIRIT – COIL & MAGNET

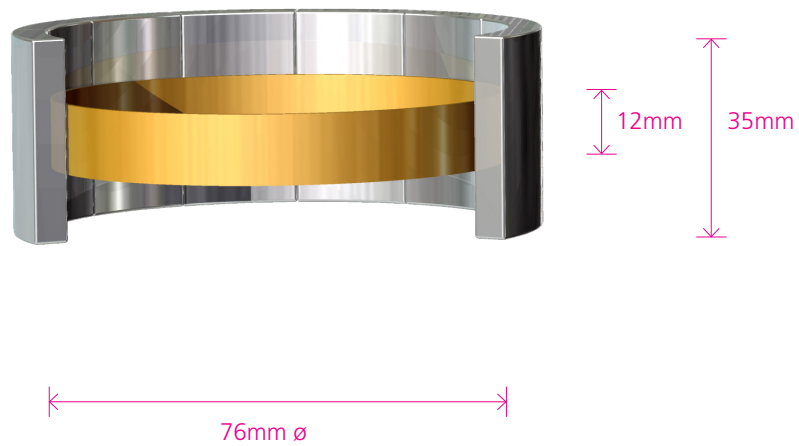

Original C225

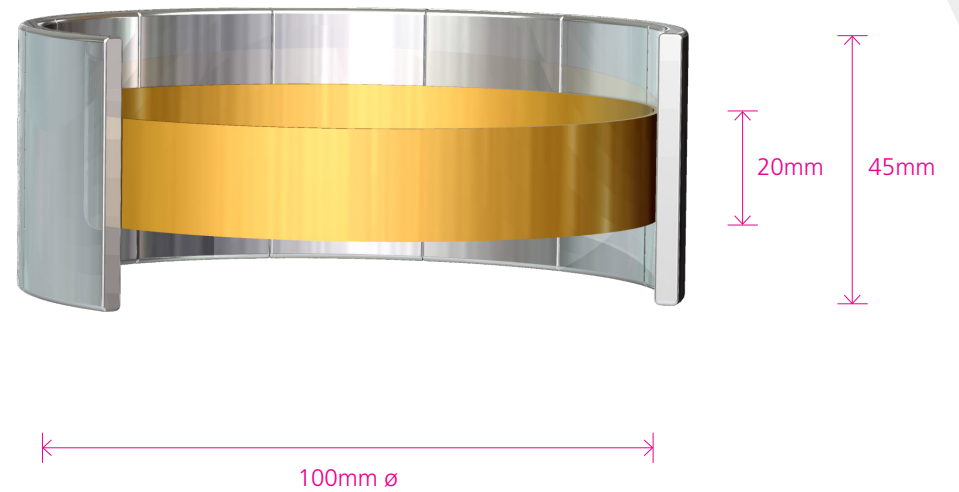

The new larger C225-100

GIYA G1 SPIRIT – PROPORTIONS

Original G1

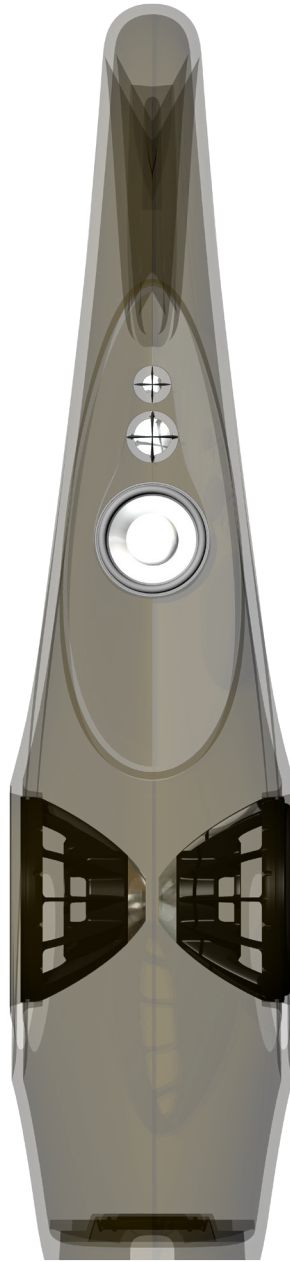

The new G1 Spirit

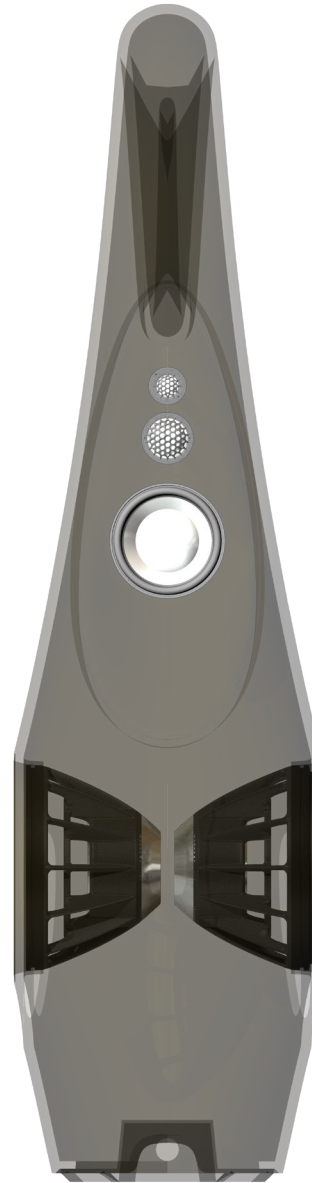

GIYA G1 SPIRIT – LOW-MID-RANGE

Standard C125S

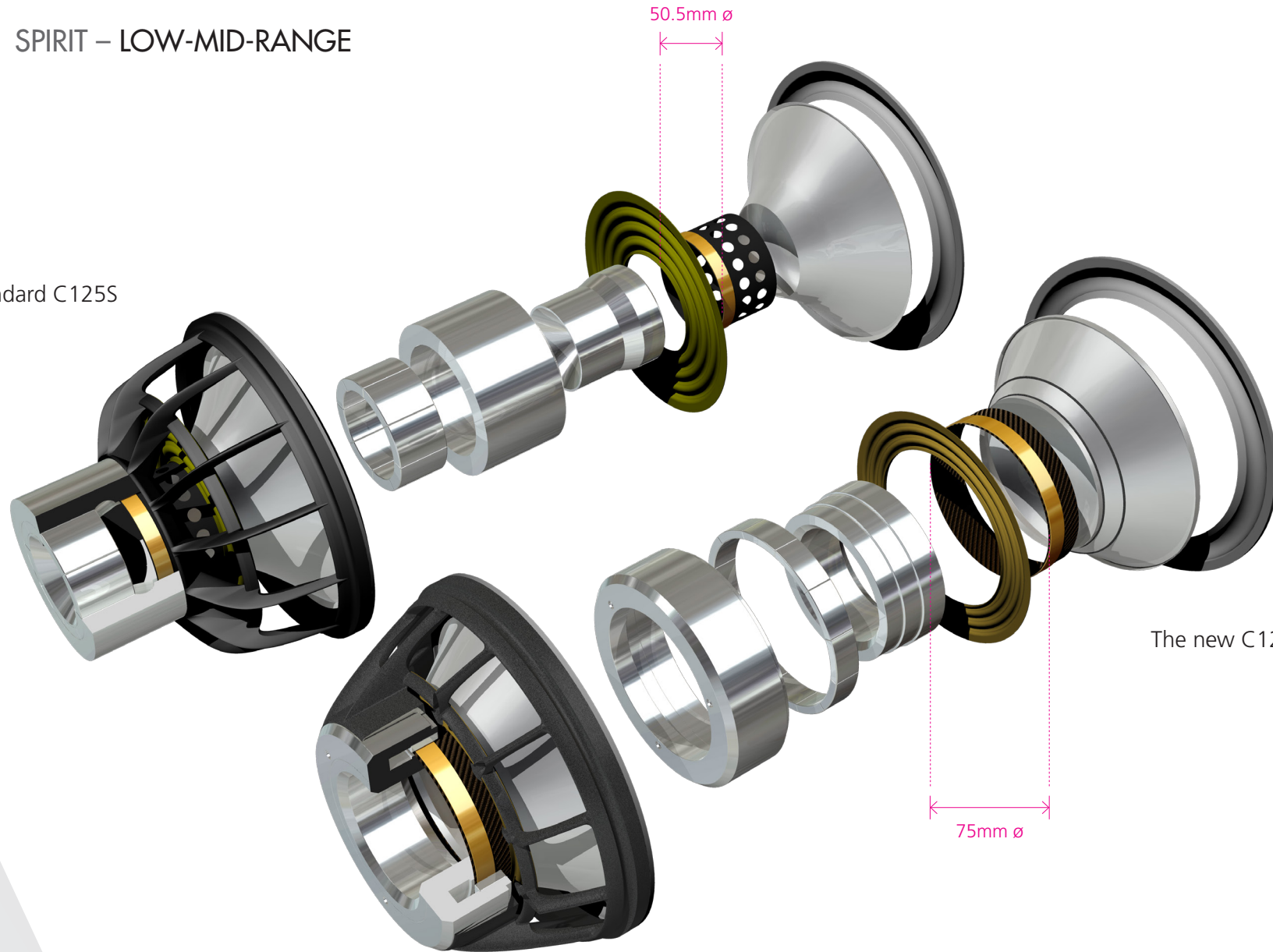

GIYA G1 SPIRIT – GRILLES

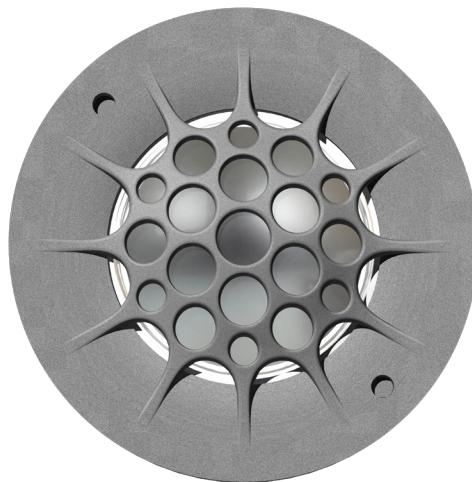

D26

The new grilles
improve protection



D50

GIYA G1 SPIRIT – ONE-PIECE MOULDED ABSORBER TUBES

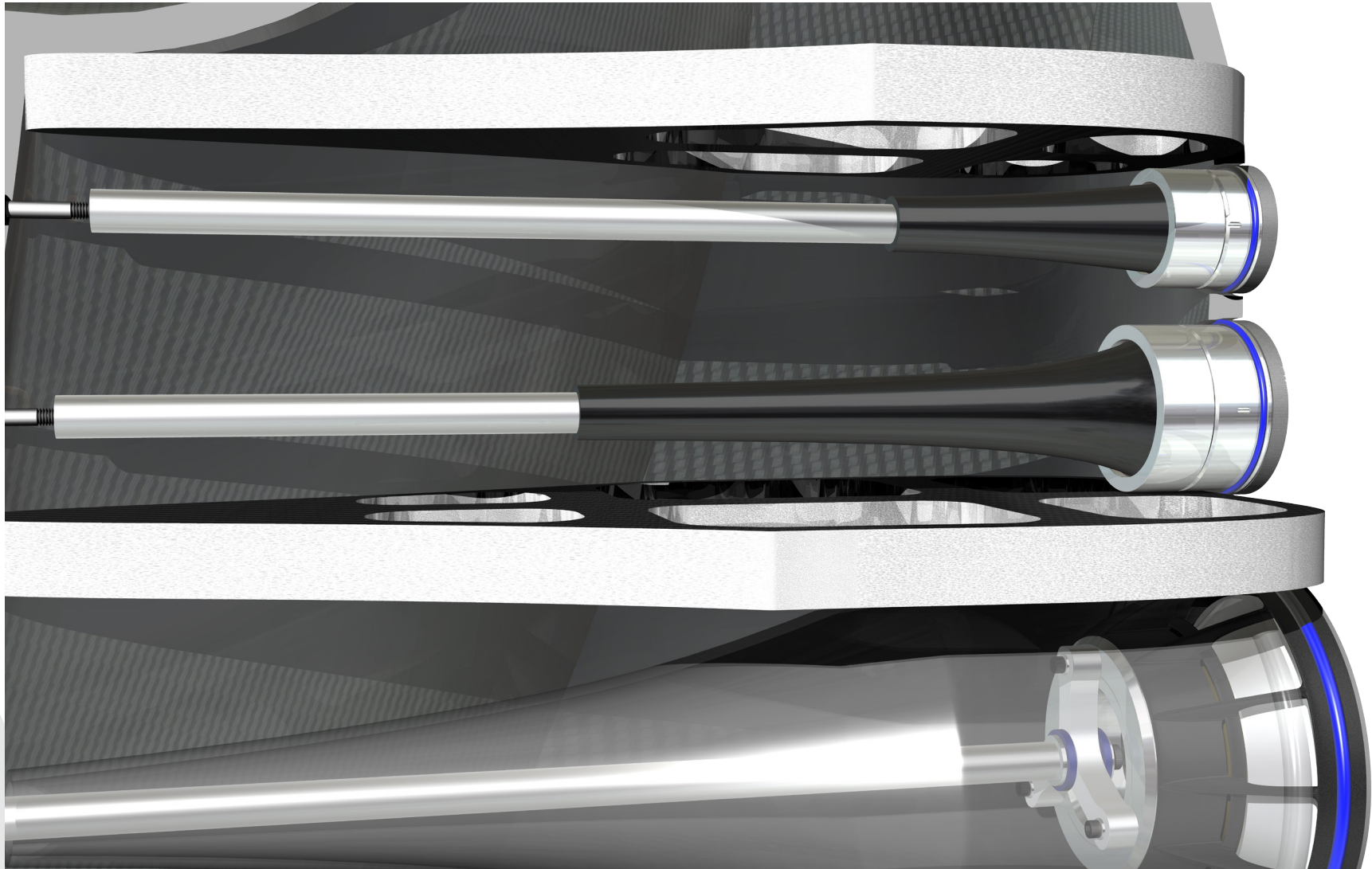

GIYA G1 SPIRIT – CARBON-SKINNED COMPOSITE GRIDS

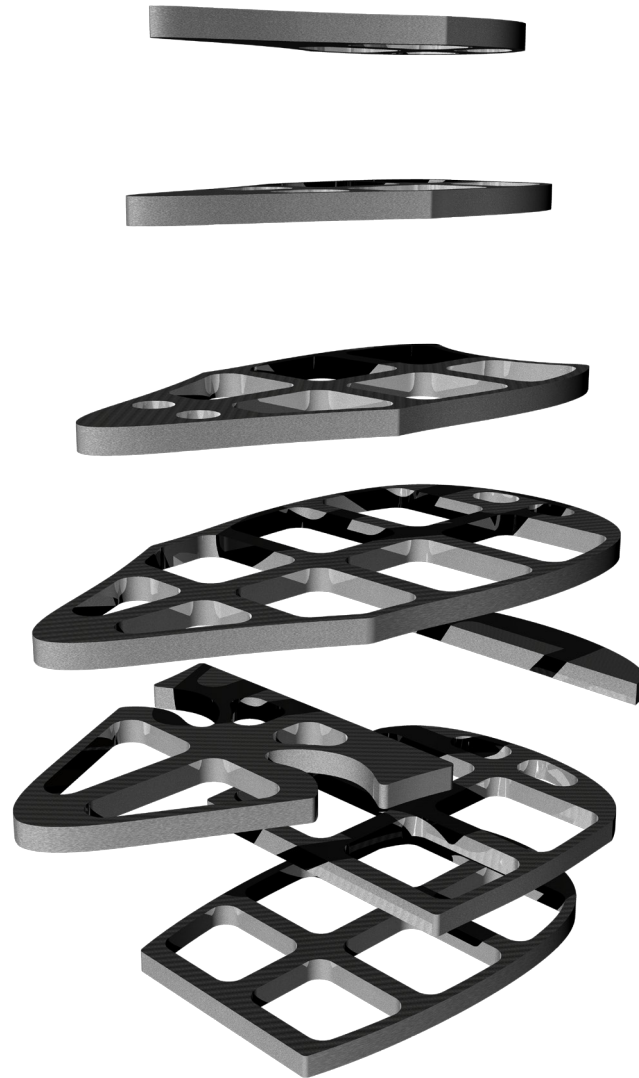

GIYA G1 SPIRIT – SPIRITUAL EXPLOSION



GIYA G1 SPIRIT – OPTIONAL OUTBOARD CROSSOVER

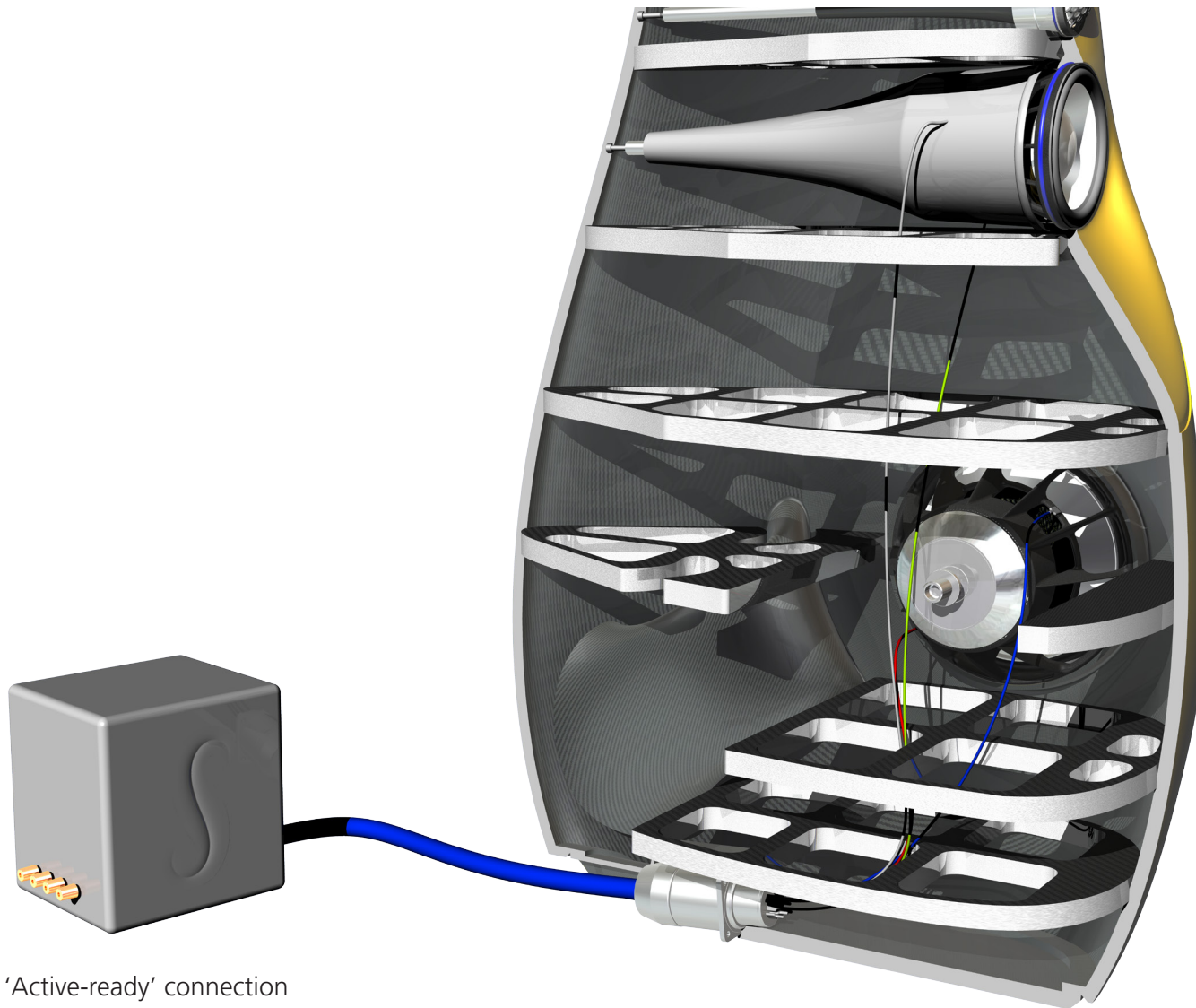



VIVID *audio*

Philip Guttentag, CEO

Telephone: +27 (0) 87 287 9871 Email: philip@vividaudio.com

Vivid Audio

41 Oppenheimer Street, Pinetown 3600, South Africa