



MOONRIVER AUDIO

---

MODEL 505

HYBRID STEREO PHONO EQ STAGE

O P E R A T I N G   I N S T R U C T I O N S



**W**elcome to the family of proud owners of fine audio components from Moonriver Audio of Sweden. Your new Moonriver component has been painstakingly designed to re-create the sound of live music taking place in its original recorded space, as well as convey the emotional connection between the performer & the listener.

Every Moonriver product is designed to cater to the needs of the most discerning audiophile & music enthusiast with distinctive styling, superb ease of use and marvellous musicality, which elevates it above the mundane world of conventional audio components.

We spent more than 2 years in research and development to achieve this high level of performance. The result is a world class phono stage with features, ergonomics and performance hard to find at any price level.

As for the sonic signature of all Moonriver Audio products, we strive to balance the fine line between musicality & resolution. The soul of the music is in the midrange, this is where most of the emotion, the passion, the *joie de vivre* is contained.

On a technical level, it's within the frequency band of 200 - 4,000Hz. Without a solid foundation underneath the midrange, the music sounds thin & brittle and often un-involving. If the brain perceives that the sound is artificial, then it's difficult to be swept away by the message contained within the music.

Similarly, accurate timbre reproduction is essential. A New York Steinway does have noticeable sonic differences from a Hamburg Steinway, while a Guarneri violin sounds distinct from a Stradivarius. To capture all those nuances, the loudspeakers & electronics need to act in unison, neither obscuring, nor exaggerating detail.

A sincere effort to achieve effortlessness.

*IMPORTANT NOTE: Before installing your new MOONRIVER AUDIO component, please read this manual carefully. It will inform you of the proper installation, correct operating procedures and of course, the product specifications.*



# Contents

## Important Safety Instructions

Unpacking And Installation

Box Contents

6

8

8

## Introduction

Moonriver Audio

Made In Sweden

The Long Playing Record

The LP as the Audiophile Format of Choice

Moon River the Song

Moonriver Model 505 Hybrid Phono Stage

Layout & Shielding

Components

Power Supply

Active gain stage

De-emphasis EQ

Microcontroller operation with memory function

Design & User Interface

Features

10

10

10

10

10

11

11

11

12

12

12

12

12

12

12

## An Introduction to Vinyl Records Reproduction

Vibration, Resonance & Materials

Bearings, Driving Mechanisms & Motors

Tone-arms & Cartridges

VTA, Overhang, Azimuth, Tracking Force & Anti-Skating

Conclusion

The Ideal Analogue Vinyl Record System

A few Words About 78rpm Gramophone Records

13

13

13

14

14

14

15

15

## Front Panel Description & Operation

Back Panel Description & Operation

16

18

Further Information for Cartridge Perfect Match

MC Low Output Cartridge Optimum Settings Guide

Custom MC Load Impedance

MC High Output Cartridge Optimum Settings Guide

MM Cartridge Optimum Settings Guide

19

19

19

20

20

Placing the Moonriver 505 Hybrid Phono Stage

Grounding

21

21

## Specifications

22

Limited Warranty

Limits of Warranty

Warning!

Troubleshooting

23

23

23

23

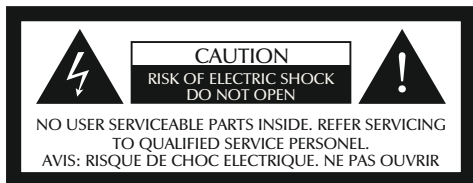

## IMPORTANT SAFETY INSTRUCTIONS

Before using your MOONRIVER AUDIO component, carefully read the applicable items of these operating instructions and the safety suggestions. Please keep these instructions in a safe place.

Before connecting a MOONRIVER AUDIO component to your audio system, turn off all other equipment. Many audio components have automatic power-on circuits that may potentially cause damage to electronic components and/or speakers. This type of damage is not covered by product warranties, and MOONRIVER AUDIO specifically disclaims responsibility for any such damage. Check the rear of the unit to ensure it is the right AC voltage for your country.

**CAUTION: Do not open the chassis of the MOONRIVER 505 while the amplifier is on or plugged into an AC wall socket. There is high voltage inside.**

Do not perform any service operations. Service is required when the unit has been damaged in any way, such as:

- mains socket is damaged
- liquid has been spilled or objects have fallen into the unit
- the unit has been exposed to rain or moisture
- the unit does not operate normally or changes in performance in a significant way
- the unit is dropped or the enclosure is damaged

Do not place the unit on an unstable box, stand, tripod, bracket or table. If the unit falls, it may cause injury to a person or damage to the unit. Mount the unit in a stable and safe place.

Slots and openings in the cabinet create ventilation to protect the component from overheating. These openings on the bottom panels must remain unobstructed. Allow at least 10cm of clearance above the unit and an opening behind the unit for airflow. Do not place the unit on a bed, sofa, rug, built-in bookcase, or rack without adequate ventilation.

Do not place near heat sources, such as radiators, heat registers, or appliances which produce heat. Keep the rear of the unit at least 10 cm from walls or other items that might block heat radiation. Do not use the unit near water (swimming pool, bath tub, kitchen sink or laundry tub) or in a damp environment like a basement or outside in the rain.

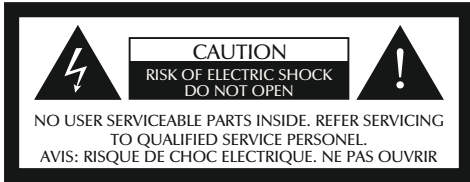

Do not step on the power cords. Do not place items on top of power cords so that they are pinched or leaned on. Pay particular attention to the cord at the plug end and the point where it connects to the unit. Do not defeat the safety purpose of the ground plug. A grounding IEC type plug has two blades and a third grounding prong. The third prong is provided for your safety. When the provided plug does not fit into your outlet, consult an electrician to replace the broken or obsolete outlet.

Do not push objects of any kind into the unit through openings as they could touch dangerous voltage points and short-out parts, possibly resulting in a fire or electric shock. Avoid spilling liquid of any kind on the unit. If water or any metal object (such as a paper clip, coin, or staple) accidentally falls inside the unit, disconnect it from the AC power source immediately and contact Moonriver Audio for further instructions.

For added protection during a lightning storm or when the component is idle for long periods of time, unplug the unit from the wall outlet. This will help protect the unit from lightning and power line surge damage.

Do not overload wall outlets, extension cords, or integral convenience receptacles as this increases the risk of fire or electric shock.

## ■ Unpacking and Installation

MOONRIVER AUDIO 505 hybrid phono stage was shipped in a carton box particularly designed to protect the contents. Special care has been taken to prevent damage during shipping. Carefully remove your new 505 phono stage from the packaging and examine it closely for signs of shipping damage. If shipping damage is discovered, take photos of the damage, contact the transport carrier immediately and retain the packing as evidence. We strongly recommend saving all original packing cartons to protect your component for storage or future shipping.

### Box Contents

User Manual x1

Power Cord x1

MOONRIVER MODEL 505 hybrid phono stage x1

Packing Material

### Silver Color Enclosure Screws

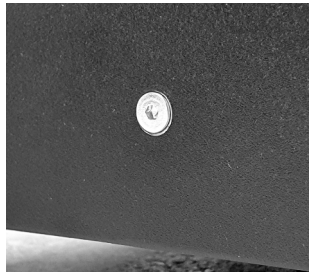

These screws are not there for decoration. They have an active role to the proper grounding of the chassis and they should always be placed in the same position.



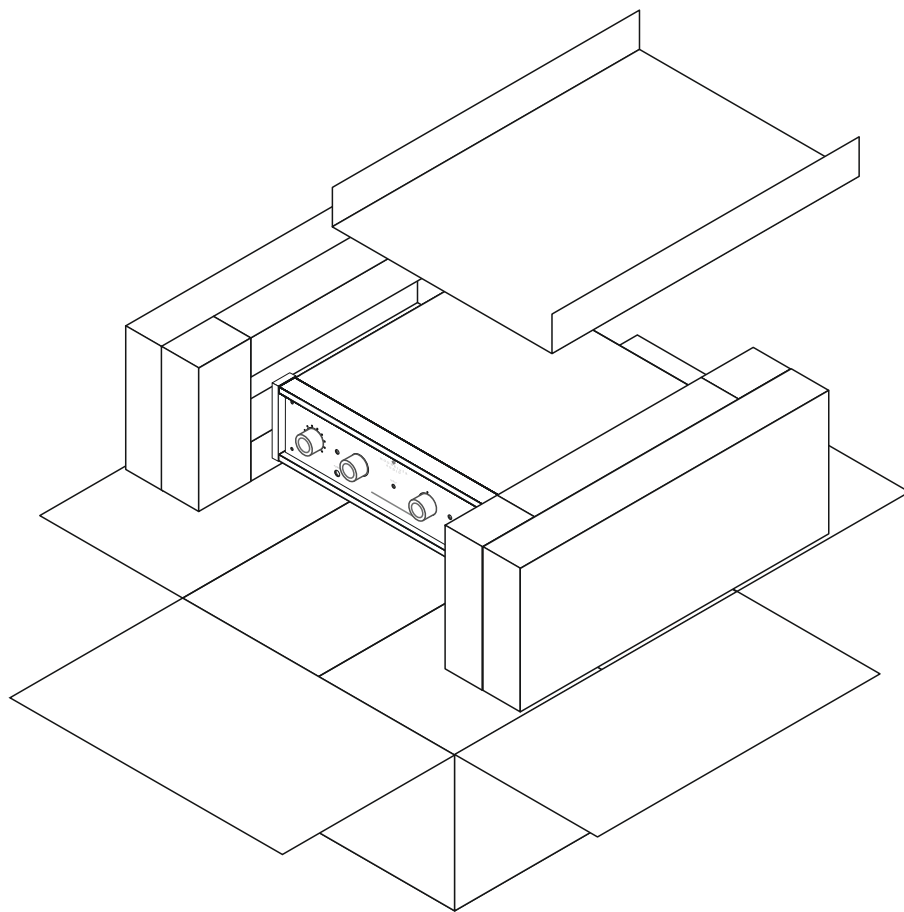

## ■ Introduction

### Moonriver Audio

Inspired by the famous song, MOONRIVER AUDIO is a combination of the vintage and the contemporary in audio reproduction.

Classic, timeless, user oriented design. Organic texture acquired within an open space, dynamic behaviour unrestrained while preserving natural colour, provisions made for modular upgrades and direct access to all functions.

Moonriver loves vinyl records, analogue tapes, compact discs and digital streams and features upgradable modules for all those formats. We employ every technology available today, without staying dogmatically exclusive to one design principle versus another, be it solid state, integrated circuit or vacuum tube. We are fond of hybrid designs that fuse well-known and fresh tech elements, but, most of all, that fit the application.

### Made In Sweden

Our products are designed and made in Sweden. We hand-assemble each unit, a painstaking but precise procedure. Through a global inventory that is constantly updated, it is our sophisticated research, efficient development and extensive listening tests -the fun part- that lead us to select the right component for a no-compromise audiophile sound.

We also care for sustainability as well as for reliability. Moonriver products are covered by a 3-year warranty and are designed to last for decades without any need of maintenance.

### The Long Playing Record

CBS Laboratories research began in 1939, but was suspended during World War II, and resumed in 1945. Columbia Records unveiled the Long Playing record (LP) at a press conference in the Waldorf Astoria on June 21, 1948, in two formats: 10 inches (25 centimeters) in diameter, matching that of 78 rpm singles, and 12 inches (30 centimeters) in diameter.

With the advent of sound film or "talkies", the need for greater storage space made 33 1/3 rpm records more appealing. Soundtracks – played on records synchronized to movie projectors in theaters – could not fit onto the mere five minutes per side that 78s offered. When initially introduced, 12-inch LPs played for a maximum of about 23 minutes per side, 10-inch records for around 15.

The 78 RPM shellac records had a play time of around five minutes. These records were fragile & broke apart if dropped. While microgroove albums had a narrower groove width which allowed a longer playback. In 1959, the last US-made 78 record was produced.

### The LP as the Audiophile Format Of Choice

Despite all the digital hype over the past 40 years, the LP remains the format of choice, both as the finest high fidelity medium and offers the widest catalogue of recorded music. Its comprehensive catalogue of titles will never be rivaled by either streaming platforms nor the compact disc.

The LP holds a very special place in our hearts here at Moonriver, as our founder & chief designer George Polychronidis has a collection of twelve turntables, six separate tonearms & forty seven cartridges, both moving magnet & moving coil.

Today, Moonriver continues to support analog playback with the full force of our considerable research and development

resources; it's essentially a labour of love. Moonriver is pushing the sonic frontier with the 505 phono stage with its separate moving coil and moving magnet circuits, high gain in order to realise the maximum dynamics from vinyl playback as well as the flexibility to coax the maximum sonic potential from either moving coil or moving magnet cartridges. All settings available at the finger tips of the music lover, not to mention that those settings are easily repeatable from the memory of each of the four separate inputs. This musical instrument will continue to enrich the lives of dedicated music lovers for years to come.

## Moon River, the Song

Is there a better song than "Moon River"? Perhaps. Yet there's no denying that it's one of the greatest songs of all time.

This beautiful song was composed by Henry Mancini, with lyrics by Johnny Mercer, the melody features prominently in the 1961 adaptation of Truman Capote's "Breakfast At Tiffany's", while the vocal version was originally performed in the same movie by Audrey Hepburn for which it won the Academy Award for Best Original Song in 1961. Though it was subsequently recorded by Andy Williams, who made it his signature song. It has since been recorded hundreds of times by artists as varied as Frank Sinatra, Louis Armstrong, Melody Gardot, Carla Bruni, Jane Monheit to Frank Ocean.

"It is to the uncompromising music lovers that we dedicate the Moonriver 505".

## ■ Moonriver Model 505 hybrid phono stage

We spent more than 2 years of research and development to design the Moonriver 505 hybrid phono stage. Our goal is to offer a world class phono stage that stands out in terms of performance, features and ergonomics.

The Moonriver Audio 505 phono stage fulfills all the needs for the present and the future for any demanding audiophile who loves vinyl records. It is designed with audiophiles, record collectors and vinyl freaks in mind. It sports 4 inputs for all your turntables, tone-arms and cartridges. It also supports every possible adjustment on the fly with dedicated knobs and switches to ideally match your MC or MM cartridge.

The hybrid design pertains to the use of ICs and discrete solid state circuits combined in an ideal form of high-performance and ultra-low noise circuitry. While the IC opamps offer very low noise levels, a discrete circuit offers life-like drive and dynamics something not possible from IC op-amps alone.

The sound and the level of performance of the Moonriver 505 phono stage is hard to describe and it must be auditioned to be believed.

## Layout and shielding

The layout of the PCB is designed with 3 principles in mind: Isolation in-between noise sources, a sensitive audio signal between the transformer and gain stages, a minimalistic approach with the least components possible in the signal path, while the shortest signal path possible.

The Moonriver 505 uses double shielding including a shielded transformer with an extra Faraday cage, one for the transformer and one for the active gain circuits. This approach eliminates the need for an external transformer and its disadvantages.

## Components

The layout is mainly based on through hole, discrete components with the exception of the input MM and MC stages with their impedance and capacitance adjustments which use surface mount components to keep the signal path as short as possible. The components are carefully chosen in order to deliver the most open and transparent sound from input to output and to reveal the texture and the micro and macro dynamic content of each record. The Moonriver 505 hybrid phono stage will reveal micro-contrast, low level information and hidden qualities never experienced before from your vinyl records.

## Power supply

The Moonriver 505 hybrid phono stage contains 6 separated power supplies include a massive 70000uf total capacitance and it is designed in dual mono operation. Each stage has its own power supply, including linear discrete regulator circuit and discrete noise rejection circuit.

## Active gain stage

Using ultra low noise active gain stages, the Moonriver 505 delivers a maximum gain of 72dB (x4000 times) in the MC setting. MM and MC settings use different input stages with different op-amps specifically chosen for each case. All setting functions are performed with air sealed, extremely low impedance relays. Finally, a discrete, high current output circuit delivers lifelike dynamics on the output.

## De-emphasis EQ

The de-emphasis circuit is passive, the best possible approach for extreme flat frequency response without interfering with the other stages. The EQ circuits involves 2 equalization curves, a RIAA and

a DECCA or COLUMBIA curve for 78rpm records. Both EQ circuits are formed using a minimalistic approach with very few, extremely low tolerance, audiophile quality components.

## Microcontroller operation with save memory function

A microcontroller controls all functions and ensures an entirely silent operation. Every setting change is stored automatically for each of the 4 inputs. Every time you change the input, the last chosen settings are recalled automatically. For example, you can connect 4 MC cartridges or 4 MM cartridges or 2MC and 2 MM, or 3 MM and one MC, every combination is possible with different settings for every input.

## Design & User Interface

We had a very clear vision when conceiving the Model 505 hybrid phono stage: Classic design with a modern touch; high quality materials such as oversized aluminium knobs, solid walnut cheeks, sturdy chassis and an ergonomic user interface.

There are no “for show” aesthetics here, no display with complicated serial menus and hidden functions, nor a single multi-function knob for “minimalistic” purposes.

The heart of the Model 505 is pure and minimal, but the interface is user-oriented and easy to operate by anyone in seconds, with no need to resort to the user manual.

## Features

Giving direct access to all necessary adjustments, the 505 includes 4 knobs and 5 switches for all the adjustments: 4 inputs, 12 gain settings (6 for MM and 6 for MC), 5 MM capacitance settings, 5 MC load settings, including a custom option, 3 MM load settings and EQ choice for RIAA, Decca or Columbia 78 rpm

records. The 505 phono stage will handle the signal from your precious MC cartridge with unmatched performance and it will make your everyday MM cartridge sound like never before.

## An introduction to vinyl records reproduction

The vinyl record invention goes long back in time. It offers a highly sophisticated, uncompressed analogue audio format which offers the closest possible approach to the analogue master tape in an affordable, commercially available format. A good vinyl record reproduction system can outperform a digital source in terms of transparency, naturalness, resolution, timing and dynamics. With the proper handling and use, a vinyl record can last for many decades and can be played thousands of times. The problem with the analogue formats is the cost, the distribution and the degradation over time since as it is a physical format. But all these disadvantages make each copy a unique item with its own history.

*The vinyl format is the only remaining, true audiophile format because it allows the user himself to tune the sound of his system by choosing the right turntable, tone-arm and cartridge and by changing the adjustments and the settings to all of them. With the Moonriver 505 hybrid phono stage you can adjust the electrical performance of your cartridge to the finest detail and to your taste on the fly.*

## Vibration, resonance and materials

The materials used for the plinth (chassis), the platter and the tone-arm are critical for the sound. The turntable is a vibrating machine in a closed loop. Vibrations from the cartridge pass to the tone-arm, to the chassis, to the platter, to the speakers and back to the cartridge. Vibration and resonances colorize the sound. A

sophisticated combination of materials and mass can cancel the resonance frequencies in a very effective way. They can cause the whole system reject the vibrations and resonances faster or slower, resulting in a different sound character as well. Softer materials have a lower resonance frequencies and harder materials have higher resonance frequencies. These differences lead to a “darker” or “brighter” sound.

## Bearings, driving mechanisms and motors

The spindle bearing assembly is a source of noise if it is not designed or lubricated correctly. There are many different designs with different advantages and drawbacks. Larger diameter spindles have higher friction and noise due to a larger perimeter but they last longer. Smaller diameter spindles are quieter due to a smaller perimeter and more effective but they can have higher tolerances in shorter time. Inverted spindle bearings allow smaller tolerances but they require a thicker and heavier platter. The thrust pad is also critical to the sound and it can also be a source of noise. There are many solutions available, even with compressed air, exotic materials or a magnetic support to reduce the friction and noise from the thrust pad.

The drive mechanism is extremely important for the sound. Low frequencies on the record act as a brake and slow down the driving mechanism. It is critical how the driving mechanism keeps up the speed stable during the small rapid changes which are impossible to measure. Belt drive mechanisms offer more laid back, slow pace and “sweet” sound due to the elasticity of the belt, while the direct drive mechanisms allow for a quieter operation, punchy and dynamic sound but with the effect of “grain” due to the stepped motor. Idler drive turntables have the advantages of both, previous mentioned, methods but with a higher rumble noise floor. Drive motors are critical for the sound and the most important is the motor isolation from the plinth and the platter.

## Tone-arms and cartridges

The tone-arm and the cartridge is probably the most important part of a good analogue, vinyl spinning system. Each tone-arm has a specific effective mass and the cartridge a specific compliance (suspension stiffness). They should match well together in order to get a well balanced sound. The resonance frequency of this combination must be between 8-12Hz. There are many calculators on the internet to find the resonance frequency of your system like this:

[https://www.vinylengine.com/cartridge\\_resonance\\_evaluator.php](https://www.vinylengine.com/cartridge_resonance_evaluator.php)

Lower resonance frequency than 8Hz will give more bass-heavy sound and less "sparkling" highs and higher resonance frequency than 12Hz will give more "thin", less "bassy" sound. All these are dependant on the cartridge character, the loading, the turntable and the tone-arm 'character', the system character and the taste of the user as well.

## VTA, overhang, azimuth, tracking force and anti-skating

VTA stands for vertical tracking angle which is the height of the tone-arm in its mounting position. This allows the tone-arm to be parallel or not to the record. If the tone-arm is higher (negative VTA), then the high frequencies will be boosted and distortion can occur. If the tone-arm is lower (positive VTA) the high frequencies will be rolled off depending on the angle.

The overhang is the most important adjustment and requires that the needle is absolutely aligned to the record groove. For the right adjustment you will need to print a protractor like this:

<https://www.vinylengine.com/cartridge-alignment-protractors.shtml>

The azimuth is the vertical angle of the needle to the record. Wrong adjustment will result in uneven wear to the record and bad stereo imaging.

The tracking force is the weight applied to the stylus in order to read the record properly. There is always a given range in grams from the manufacturer.

The anti-skating force is the method to keep the tonearm aligned when "reading" of the grooves. The anti-skating force is critical for proper imaging and a wrong setting will unduly wear the record and the stylus.

## Conclusion

In conclusion, vinyl record reproduction is a fascinating experience and it can give an extremely high performance level, not possible with other commercially available formats. In general, the turntable plinth (chassis) and platter and its driving mechanism is responsible mainly for the timing and secondary for the tonality of the system. The main responsibility of the tone-arm is the recreation of the sound stage and to allow the cartridge to do its job without adding any coloration. The cartridge itself has its own tonal character which can be fine tuned by the tone-arm and the settings of the phono stage.

## The ideal analogue vinyl record reproduction setup

Since the use and production of vinyl records already spans already more than 70 years, the recording and pressing methods have been changed drastically over the decades. From the exclusive use of all analogue, usually tube based, stand alone equipment in the 50s and 60s and analogue tape recorders up to the 80s, modern recordings and productions usually are finalized just in a DAW (Digital Audio Workstation) software entirely using digital tools. It is also common that the entire music is created completely using software instruments directly inside the DAW. This means that the quality difference between various recordings over all these decades is enormous.

To be able to enjoy your favourite music when the recording, production or pressing has poor quality, there is a simple and effective solution:

You will need 2 turntables or one turntable with 2 tone-arms with different cartridges. One with a “forgiving” affordable, MM cartridge with an elliptical needle and one expensive with a “revealing” (usually MC) cartridge with fine line, Shibata or line contact, etc needle tip. This setup allows to reduce and devote the use of your expensive MC cartridge only to your best sounding records and use the MM for all the rest.

## A few words about 78rpm gramophone records

The 78rpm gramophone shellac record standard was established in 1912 and the first recordings were acoustical without the use of electricity. In the beginning of the 1920s the first electrical recordings took place and they were based on vacuum tubes. The 78rpm era ended in the early 50s with the evolution of the microgroove record. All the 78rpm recordings were made with a direct cutting method without the interference of the magnetic tape. This method is well known as the best for the sound quality because it doesn't compress the dynamic range or degrade the quality due to the transferring process. Many of these recordings from that era sound incredible fresh and involving even today and they are waiting to be re-discovered. The Moonriver 505 hybrid phono stage offers an EQ curve for the most common 78rpm records: The Decca EQ standard which was the most common in Europe and the Columbia EQ standard for the U.S. The Moonriver 505 comes with Decca as a standard but it can be ordered with the Columbia EQ curve as well.

# FRONT PANEL DESCRIPTION AND OPERATION

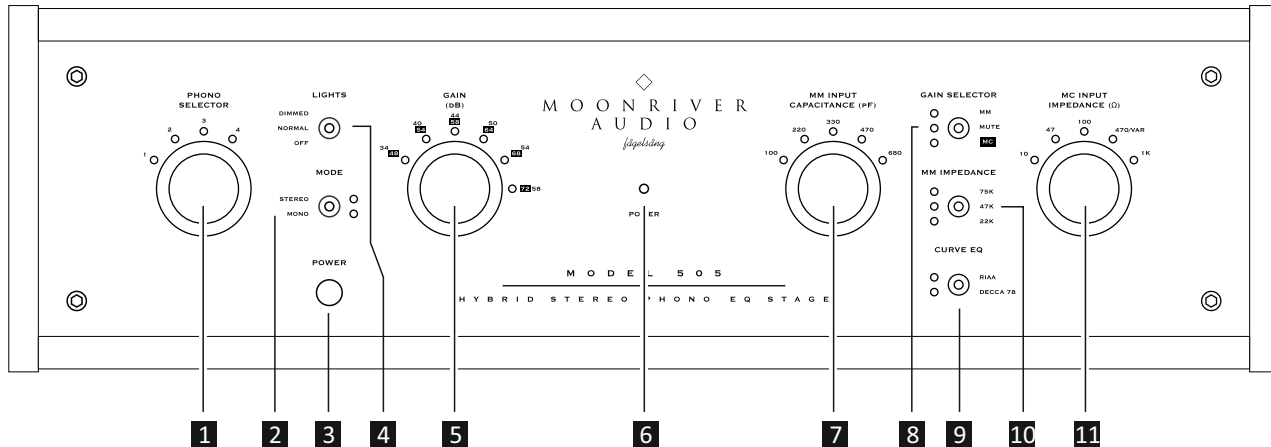

## 1 PHONO SELECTOR

Turning the source selector clockwise selects the next phono cartridge and counter-clockwise the previous one. There are 4 positions from 1 to 4. Each time an input is chosen, the last saved settings of this input are restored.

## 2 MODE SWITCH

This switch converts the signal from stereo to mono. It should be used to old monaural 33 & 45 rpm analogue recordings or 78rpm records. The setting is saved in the chosen input automatically.

## 3 POWER SWITCH

Turns the unit on or off. The off position doesn't consume any power. **CAUTION:** If you just turned off the unit, please wait at least 30 seconds before you turn it on again.

## 4 LIGHTS SWITCH

This switch changes the light's luminosity. There are 3 options: Normal, Dimmed (50% of the normal) and off.

## 5 GAIN SETTING

Turning the gain knob clockwise, you increase the gain and counter-clockwise, decrease the gain. There are 2 gain ranges, one for MM (34,40,44,50,54,58dB) and one for MC (48,54,58,64,68,72dB). The setting is saved in the chosen input automatically. *See below for more information.*

## 6 POWER LED

It show the status of the power. When the unit turns on, the light is activated.

## 7 MM INPUT CAPACITANCE SELECTOR

Turning the capacitance selector clockwise you increase the capacitance and counter-clockwise you can decrease it. The capacitance adjustment is activated only when the MM setting is chosen in the GAIN SELECTOR. The capacitance range is 100, 220, 330, 470, 680pF. The setting is saved in the chosen input automatically. *See below for more information.*



### 8 GAIN SELECTOR & MUTE FUNCTION

The gain selector switch chooses the type of cartridge. You can choose between MM, MUTE and MC. The mute function is activated automatically and it flashes for 2 seconds every time you change the setting of MODE, GAIN, MM INPUT CAPACITANCE, GAIN SELECTOR, MM IMPEDANCE, CURVE EQ and MC INPUT IMPEDANCE. The setting is saved in the chosen input automatically. *See below for more information.*

### 9 CURVE EQ

A momentary switch changes the de-emphasis (equalization) curve. There are 2 settings available: RIAA and DECCA 78 for 78 rpm records made with DECCA equalization curve. A COLUMBIA curve is also available instead of DECCA, for 78rpm records made with the COLUMBIA EQ curve. The setting is saved in the chosen input automatically. *See below for more information.*

### RECOMMENDED GAIN SETTING REGARDING THE MM CARTRIDGE OUTPUT LEVEL

OUTPUT LEVEL (MM)	GAIN SETTING (dB)
8mV	34
4mV	40
2,5mV	44
1,25mV	50
0,8mV	54
0,5mV	58

### 10 MM IMPEDANCE

A momentary switch changes the MM input impedance when MM is chosen in the GAIN SELECTOR. There are 3 settings, 75, 47, 22K. The setting is saved in the chosen input automatically. *See below for more information.*

### 11 MC INPUT IMPEDANCE

This is the most important setting for MC cartridges along as the GAIN SELECTOR. The available settings are 10R, 47R, 100R, 470R/VAR, 1Kohms. The 470R/VAR option offers continuous input impedance adjustment from 0-820 Ohms. The default setting is 470R (ohms) but it is possible to be adjusted in any desired impedance up to 820 ohms. The setting is saved in the chosen input automatically. *See below for more information.*

### RECOMMENDED GAIN SETTING REGARDING THE MC CARTRIDGE OUTPUT LEVEL

OUTPUT LEVEL (MC)	GAIN SETTING (dB)
1,6mV	48
0,8mV	54
0,5mV	58
0,25mV	64
0,15mV	68
0,05-0,1mV	72

# BACK PANEL DESCRIPTION AND OPERATION

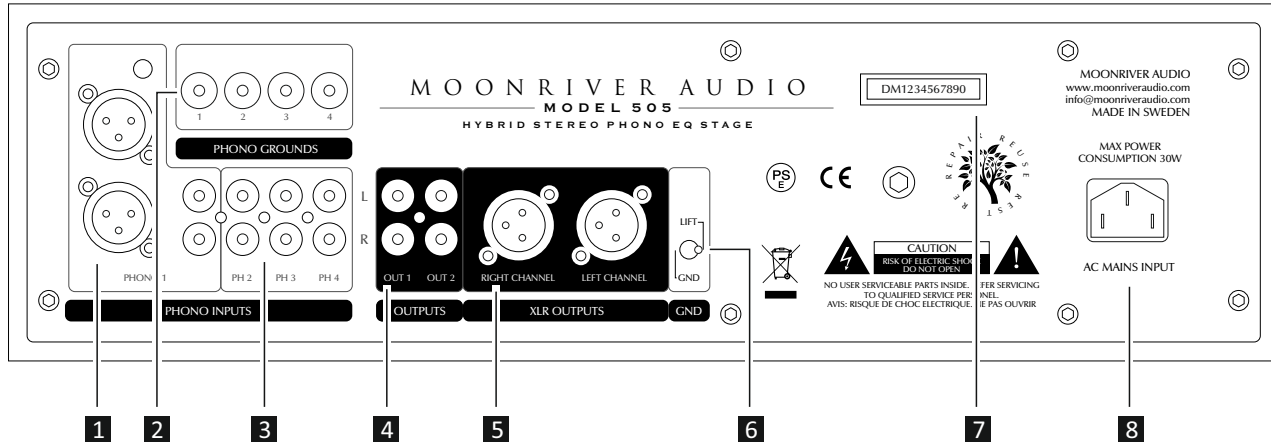

## 1 XLR INPUTS ON INPUT 1

You can connect your balanced tonearm cables here. The RCA inputs are connected in parallel with the XLR inputs.

## 2 PHONO GROUNDS

These are the ground terminals for all your ground wires.

## 3 PHONO INPUTS

The Moonriver 505 hybrid phono stage comes with 4 inputs which can be used in any combination for MM or MC cartridges.

## 4 RCA OUTPUTS

There are 2 RCA outputs to drive additional preamplifiers or headphone amplifiers. The output impedance is 100 ohms.

## 5 XLR OUTPUTS

There is an XLR output connected in parallel to the RCA outputs. The XLR output is pseudo-balanced and it should NOT be used together with the RCA outputs.

## 6 GROUND LIFT SWITCH

The ground lift switch disconnects or not the ground of the circuit from the mains ground. This is the default setting (lifted). In some cases it must be turned to ground. Choose the most quiet option for your system. *See below for more information.*

## 7 SERIAL NUMBER

The serial number carries useful information for the unit.

## 8 MAINS INPUT

Mains input must be connected to a grounded power line.

## ■ Further information for perfect match with your cartridge.

### MC low output cartridge optimum settings guide

In order to achieve the best possible settings for your MC low output cartridge, you have to follow 3 basic steps:

1. Please read carefully the specifications of your MC cartridge, using the owners manual or the vinyl engine database ([www.vinylengine.com](http://www.vinylengine.com)). Find the recommended load impedance or the coil resistance and the maximum output in millivolts (for example 0.5mV). This is the basic information you will need.

2. Adjust the MC INPUT IMPEDANCE in order to be at least 10 times greater than the coil resistance. The increment of loading impedance gives wider bandwidth which opens up the sound in both ends of the spectrum (bass and treble). Usually, the manufacturer recommends 10 times higher resistance (impedance) but this is not always the case. Then, adjust the GAIN SETTING to a desired level, according the output level in mV from the cartridge specifications. For example a 0.5mV MC cartridge with a 10 ohms coil will start to sound good with 100 ohms input impedance and 60dB of gain ( $60\text{dB} = 1000 \text{ times} - 0.5\text{mV} \times 1000 = 500\text{mV}$ ). For reference a typical consumer digital source has an output peak to peak level of 2V.

3. Now, you can start making some listening tests. As you increase the MC INPUT IMPEDANCE, the bandwidth will be expanded and vice versa. As you increase the gain via the GAIN SETTING, the sound becomes more dynamic. Laid back sound requires lower

gain, dynamic (live) sound requires higher gain. Keep in mind that 3dB of gain is double the sound level, since the dB range is logarithmic. The difference between 58dB and 62dB is big!

### Custom MC load impedance

In order to adjust the custom setting instead of 470R, you will need the following tools:

A hex screwdriver for the cover, a Philips screwdriver for the Faraday cage, a small flat screwdriver for the trimmer adjustment and a multimeter.

1. Switch off the unit and disconnect the power cord
2. Remove carefully the cover and the bottom using the hex screwdriver
3. Unlock the Faraday cage by aligning the extension locks on the bottom
4. Remove the big Faraday cage on the right, by removing the 3 Philips screws. Move it to the front direction and lift it. Be extremely careful when you remove it without using force.
5. Locate the 2 trim-pots TRMC1, TRMC2 close to the RCA inputs and follow the instructions printed on the PCB for the "custom MC load adjustment".
6. Adjust the multimeter to Ohms range up to 1kohm and place the red lead to TRP1 and the black to 0V to adjust the left channel load impedance. Repeat the same with the TRP2 for the right channel.

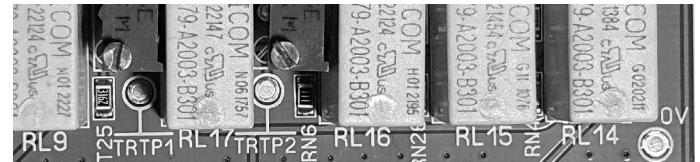

7. Available adjustments:

For **220R** load, adjust TRMC1 and TRMC2 to get **290R** in the multimeter

For **330R** load, adjust TRMC1 and TRMC2 to get **500R** in the multimeter

For **470R** load (default), adjust TRMC1 and TRMC2 to get **890R** in the multimeter

For **680R** load, adjust TRMC1 and TRMC2 to get **2,15K** in the multimeter

For **820R** load, adjust TRMC1 and TRMC2 to get **4,58K** in the multimeter

6. After finishing the adjustment, replace all the parts following the same steps in reverse order.

## MC high output cartridge optimum settings guide

MC high output cartridges use the MC (moving coil) principle, but with a larger coil to achieve higher output. In order to achieve the best possible settings for your MC high output cartridge, you have to follow 3 basic steps:

1. Please read carefully the specifications of your MC high output cartridge, using the owners manual or the vinyl engine database ([www.vinylengine.com](http://www.vinylengine.com)). Find the recommended load impedance or the coil resistance and the maximum output in millivolts (for example 1.5mV). This is the basic information you will need. The recommended setting for MC high output cartridge is the MM input setting (GAIN SELECTOR).

2. Adjust the MM INPUT IMPEDANCE according to your choice in order to be at least 20 times or more greater than the coil resistance. The MM INPUT IMPEDANCE setting has 3 options,

22K, 47K and 75K. The increment of loading impedance gives wider bandwidth which opens up the sound in both ends of the spectrum (bass and treble). Usually, the manufacturer recommends 40 times higher resistance (impedance) for the MC high output cartridge but this is not always the case. Then, adjust the GAIN to a desired level, according the output level in mV from the cartridge specifications. For example a 1.5mV MC high output cartridge with a 100 ohms coil will start to sound good with at least 1K ohms input impedance and 48dB of gain ( $48\text{dB}=252$  times –  $1.5\text{mV}\times 252=378\text{mV}$ ). The recommended setting is MM input setting (GAIN SELECTOR), with 22K MM INPUT IMPEDANCE and 50dB in the GAIN SELECTOR. For reference a typical consumer digital source has an output peak to peak level of 2V.

3. Now, you can start making some listening tests. As you increase the MM INPUT IMPEDANCE, the bandwidth will be expanded and vice versa. As you increase the gain via the GAIN SELECTOR, the sound becomes more dynamic. Laid back sound requires lower gain, dynamic (live) sound requires higher gain. Keep in mind that 3dB of gain is double the sound level, since the dB range is logarithmic. For example the difference between 58dB and 62dB is big!

## MM cartridge optimum settings guide

In order to achieve the best possible settings for your MM cartridge, you have to follow 3 basic steps:

1. Please read carefully the specifications of your MM cartridge, using the owners manual or the vinyl engine database ([www.vinylengine.com](http://www.vinylengine.com)). Find the recommended load impedance (usually 47K) or the coil resistance and the maximum output in millivolts (for example 2.5mV). This is the basic information you will need.

2. Adjust the MM INPUT IMPEDANCE according to your choice in order to be at least 20 times or more greater than the coil resistance. The MM INPUT IMPEDANCE setting has 3 options, 22K, 47K and 75K. The increment of loading impedance gives wider bandwidth which opens up the sound in both ends of the spectrum (bass and treble). Usually, the manufacturer recommends 40 times higher resistance (impedance) for the MC high output cartridge but this is not always the case. Then, adjust the GAIN to a desired level, according the output level in mV from the cartridge specifications. For example a 1.5mV MC high output cartridge with a 100 ohms coil will start to sound good with at least 1K ohms input impedance and 48dB of gain ( $48\text{dB}=252$  times –  $1.5\text{mV}\times 252=378\text{mV}$ ). The recommended setting is MM input setting (GAIN SELECTOR), with 22K MM INPUT IMPEDANCE and 50dB in the GAIN SELECTOR. For reference a typical consumer digital source has an output peak to peak level of 2V.

3. Now, you can start making some listening tests. As you increase the MM INPUT IMPEDANCE, the bandwidth will be expanded and vice versa. As you increase the gain via the GAIN SELECTOR, the sound becomes more dynamic. Laid back sound requires lower gain, dynamic (live) sound requires higher gain. Keep in mind that 3dB of gain is double the sound level, since the dB range is logarithmic. For example the difference between 58dB and 62dB is big!

**Remember that the final adjustments must be made only by you, depending of your system and your taste.**

The unique, adjustment feature of the Moonriver 505 hybrid phono stage allows “on the fly” listening tests with various adjustments without the need to switch off, remove the cover, switch on again and wait to warm it up.

## Placing the Moonriver 505 hybrid Phono Stage

Please pay special attention in the placement of Moonriver 505 phono stage. Since phono stages use huge amplification gain, they are very sensitive to noise sources such as transformers, mobile phones, network routers, power distributors, etc.

A phono stage must be placed away from noise sources and as close as possible to the turntable since the tone-arm cables carry a very low level signal. These cables should be placed away from power cables as well. Use only coaxial shielded cables to connect your turntable to the Moonriver 505.

## Grounding

If noise occur, change the ground lift switch position. The default setting is LIFT if your amplifier is already grounded. If it is not, you should change the switch to GROUND. In this case, your amplifier will be connected to the ground through the Moonriver 505.

If your cartridge has a metal body and the body is connected internally to one of the ground pins, you may experience ground loop noise if your tone-arm and your headshell is metallic. In this case, you must isolate the cartridge body from the headshell using plastic screws and electrical tape. In some rare cases, the tone-arm ground wire should be disconnected.

**A proper setup must have only one device connected to the mains ground, since the rest of the devices are connected to the ground through the audio cables.**

The Moonriver 505 phono stage should be placed away from electromagnetic fields, such as WIFI enable devices, mobile phones or big transformers often found in amplifiers.

## ■ Specifications

Inputs:	4 with automatic saving feature for each input
MM gain:	34, 40, 44, 50, 54, 58dB
MC gain:	48, 54, 58, 64, 68, 72dB
MM Capacitance values:	100, 220, 330, 470, 680pf
MC load impedance values:	10R, 47R, 100R, 470R (variable 0-820R), 1K $\Omega$
MM load impedance:	22K, 47K, 75K $\Omega$
De-emphasis curve:	RIAA and Decca or Columbia
Stereo / Mono function:	for 78rpm & monophonic records
Inputs & Outputs:	XLR and RCA
Output impedance:	less than 100 ohms
Dimensions (mm):	430 (W) x 390 (D) x 135 (H)
Weight:	11 kg
Features:	Microcontroller control with LED indicators   Auto mute function   Separate shielding for the transformer and gain stages   More than 70000uf total capacitance   Dual mono power supplies in all stages

## Limited Warranty

MOONRIVER AUDIO warrants that your newly purchased hardware product shall be free from defects in material and workmanship for three (3) years, beginning from the date of purchase. Shipping charges are paid by the owner. Except where prohibited by applicable law, this warranty is non transferable and is limited to the original purchaser. This warranty gives you specific legal rights; you may also have other rights that vary under local laws.

## Limits Of Warranty

This warranty does not cover problems or damage resulting from accident, abuse, misapplication, or any unauthorized repair, modification or disassembly; improper operation or maintenance, usage not in accordance with product instructions or connection to improper voltage supply.

## Warning!

MOONRIVER AUDIO LABORATORY SHALL ALSO NOT BE LIABLE FOR ANY SPECIAL, INDIRECT, INCIDENTAL, OR CONSEQUENTIAL DAMAGES WHATSOEVER, CAUSED BY PROBLEMS IN THE MAINS ELECTRIC SUPPLY, NON PROPER USE OR USE WITH NON COMPATIBLE APPLIANCES WITH INCOMPATIBLE OPERATING VOLTAGE. IN ANY CASE THE LIABILITY OF MOONRIVER AUDIO LABORATORY IS LIMITED STRICTLY TO THE INITIAL VALUE OF THE UNIT. Some jurisdictions do not allow the exclusion or limitation of special, indirect, incidental, or consequential damages, so the above limitation or exclusion may not apply to you.

## Troubleshooting

Incorrect operations are often mistaken for trouble and malfunctions. If you think that there is something wrong with this component, check all the connections, the power switch and the indicating lights. Sometimes the trouble may lie in another component. Investigate the other components and electrical appliances being used. If the trouble cannot be rectified even after checking everything, return your MOONRIVER AUDIO device to your dealer to carry out repair work.







MOONRIVER AUDIO Poststugan 532, 21165 Malmö, Sweden  
[www.moonriveraudio.com](http://www.moonriveraudio.com) | Tel: +46765905066 | email: [info@moonriveraudio.com](mailto:info@moonriveraudio.com)

